

Champ MLL LED luminaires

Cl. I, Div. 2, Groups A, B, C, D
Cl. I, Zone 2
Cl. II, Div. 1, Groups F, G
Cl. III

UL Listed
CSA Certified
Marine & Wet Locations
NEMA 4X; IP66

2L

The Champ® MLL linear LED is specifically designed to replace fluorescent T12, T8 and T5HO lighting in harsh and hazardous applications. The rugged and durable design features the industry's most versatile and flexible mounting options. The Champ MLL is the ideal solution for high vibration, impact and hose down applications.

Model	Typical lumens	Watts	Lumens per watt	Equivalent HID luminaire	Typical energy savings / lifetime
MLL2	3,600	29	124	T12HO	Up to 67%
				T8HO	Up to 63%
				T5HO	Up to 52%
				T12	Up to 42%
				T8	Up to 32%
				T5	Up to 17%
MLL4	7,100	54.5	130	T12HO	Up to 64%
				T8HO	Up to 60%
				T5HO	Up to 50%
				T12	Up to 46%
				T8	Up to 32%
				T5	Up to 22%

Applications:

- Oil and gas refineries, petrochemical facilities, food and beverage facilities, platforms, loading docks, tunnels, outdoor wall and stanchion mounted general area lighting, and where flammable vapors, gases, ignitable dusts, fibers or flyings are present

Features:

- Industry-leading efficacy: up to 130 LPW
- -40°C to +65°C ambient operating temperature (standard model)
- Low profile fixture (<3" height)
- Versatile ceiling/swivel, wall, flush, pole and pendant mounting options
- Wide and narrow optics for uniform illumination
- Four points of secondary retention
- 2,000 PSI high pressure hose rated
- High vibration resistance
- Emergency battery back-up (90 minutes) and surge protection options (up to 10kV)^A
- DesignLights Consortium® Qualified (some models are not DLC qualified)^B
- 5 year fixture warranty

Standard materials:

- Housing – copper-free aluminum; Corro-free epoxy powder coat (optional)
- Lens – glass; polycarbonate, diffused glass, diffused polycarbonate (optional)

Photometrics:

- Complete photometrics can be found at www.crouse-hinds.com/photometrics

Temperature performance data:

Ambient temp. °C	Min. temp. supply wire °C	Simultaneous rating		
		Class I, Div. 2	Class II, Div. 1	Class I, Div. 2; Class II, Div. 1
40	60	T6	T6	T6
55	75	T5	T5	T5
65	90	T5	T5	T5



Mounting (ordered separately):

Versatile mounting options:

- Flush back mount
- Swivel/ceiling back mount
- Offset ceiling mount
- Offset wall mount
- Pole mount
- Pendant mount

Easily retrofit to:

- Existing Pauluhn™ DuraPro and MagnaPro fluorescent light fixtures
- Rig-A-Lite™ and Snelson® C1D2 fluorescent lighting fixtures

Certifications and compliances:

NEC:

- Class I, Division 2, Groups A, B, C, D
- Class I, Zone 2
- Class II, Division 1, Groups F, G
- Class III
- NEMA 4X, IP66
- Marine and wet locations

UL standards:

- UL844 – Electrical Fixture Hangers for Hazardous Locations
- UL1598 – Luminaire
- UL1598A – Luminaire for Installation on Marine Vessels
- UL924 – Emergency Lighting

CSA standard:

- C22.2 No. 137

Additional certifications:

- ABS design assessed

Electrical ratings:

	MLL2	MLL4
Lumen output	3,600	7,100
Frequency	50/60 Hz	50/60 Hz
Voltage	100-277 VAC, 108-250 VDC; 347-480 VAC	

Model	Voltage	Current (A)	Watts	Power factor	THD
MLL2/UNV1	100	0.28	28.2	0.90	<20%
MLL2/UNV1	277	0.12	29.4	0.90	<20%
MLL2/UNV34	347	0.09	29.2	0.90	<20%
MLL2/UNV34	480	0.07	30.1	0.90	<20%
MLL4/UNV1	100	0.55	55.0	0.95	<20%
MLL4/UNV1	277	0.20	54.5	0.95	<20%
MLL4/UNV34	347	0.16	55.8	0.95	<20%
MLL4/UNV34	480	0.12	56.2	0.95	<20%

Weights:

Model	Lbs.	Kg.
MLL2	12.50	5.70
MLL4	22.50	10.20

^A One year warranty.

^B Refer to www.designlights.org Qualified Products List under Family Models for full listing details. Not all models are approved for all application categories.

Champ MLL LED Luminaires

Cl. I, Div. 2, Groups A, B, C, D
Cl. I, Zone 2
Cl. II, Div. 1, Groups F, G
Cl. III

UL Listed
CSA Certified
Marine & Wet Locations
NEMA 4X; IP66

2L

2L

Designed for harsh and hazardous. Champ MLL linear LED luminaires are engineered to handle demanding conditions. The MLL stands up to high vibration, hose down, shock and impact, while delivering long life and high lumen performance for up to 20 years.

Custom optics:

- Standard wide (120°) beam spread for control room and indoor application maximizes illumination on wall panels
- Narrow (80°) beam spread option for targeted illumination; avoids spillage and light loss

Comprehensive certification:

- Single model certified for use in Class I, Division 2 and Class II, Division 1 harsh and hazardous applications

Quick & easy installation:

- Easy access to drivers and wiring
- No custom brackets or hardware needed
- Seven mounting options available



Slim profile:

- 2.7" fixture height (excluding mounting brackets)
- Perfect for mounting in confined or low height areas

Built to last:

- Ingress protection from hose down water or diesel fuel in harsh operational conditions – passed 2,000 PSI high pressure test
- Vibration-, impact- and shock-resistant – passed 5G, 3-axis vibration test
- 60,000 hour lifetime at 55°C ambient



Best-in-class efficacy:

- Up to 130 lumens per watt

Champ MLL LED luminaires

Cl. I, Div. 2, Groups A, B, C, D
Cl. I, Zone 2
Cl. II, Div. 1, Groups F, G
Cl. III

UL Listed
CSA Certified
Marine & Wet Locations
NEMA 4X; IP66

2L

2L

Ordering information:

Part number example

MLL4N/UNV1 S903 TF P EM1

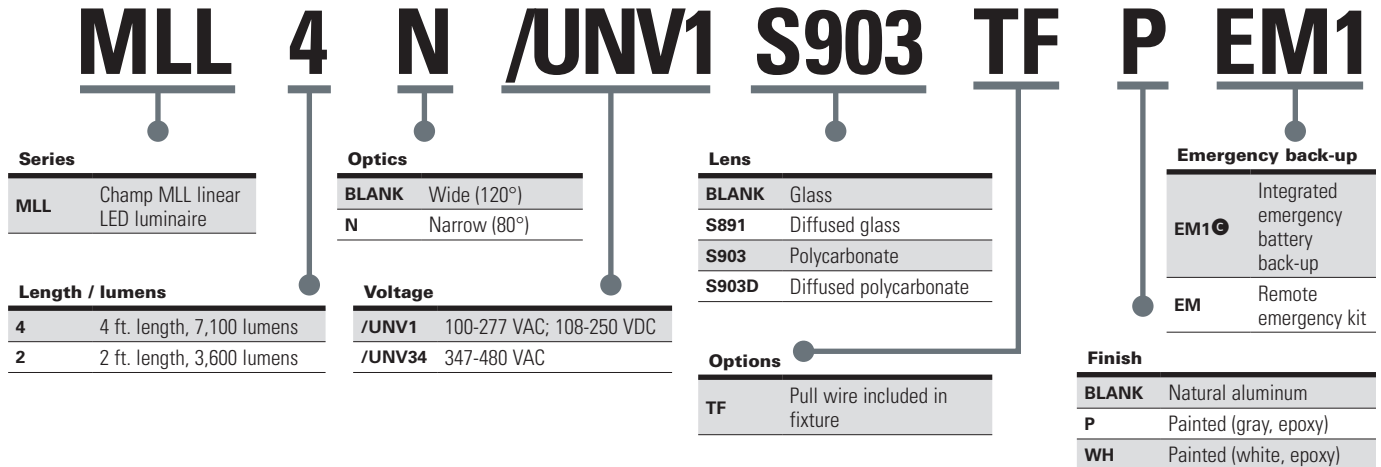

Accessories (ordered separately):

Description	Cat. #	Description	Cat. #
• Flush/back mount back plate.....	DP1057MTK	• Pendant mount kit.....	PEND HAZ KIT
<i>Compatible with DuraPro</i>		• Safety chain kit.....	SS KIT
• Ceiling/swivel mount.....	DP1050MTK	• 1 amp driver replacement kit, 100-277 VAC for 4 ft. linear.....	VMVL/UNV1 80W 1A KIT
<i>Compatible with DuraPro</i>		• 1 amp driver replacement kit, 347-480 VAC for 4 ft. linear.....	VMVL/UNV34 80W 1A KIT
• Ceiling/wall mount offset.....	DP1053MTK	• 0.5 amp driver replacement kit, 100-277 VAC for 2 ft. linear.....	VMVL/UNV1 80W 0.5A KIT
<i>Compatible with DuraPro</i>		• 0.5 amp driver replacement kit, 347-480 VAC for 2 ft. linear.....	VMVL/UNV34 80W 0.5A KIT
• Ceiling mount bracket and adapter kit.....	MP1054MTK KIT		
<i>Compatible with MagnaPro</i>			
• Offset wall mount.....	DP1052MTK		
<i>Compatible with DuraPro</i>			
• Pole mount kit, 1.25" conduit.....	PM KIT 1.25		
• Pole mount kit, 1.50" conduit.....	PM KIT 1.5		
• Pole mount kit, 2.00" conduit.....	PM KIT 2.0		

Dimensions and mounting options:

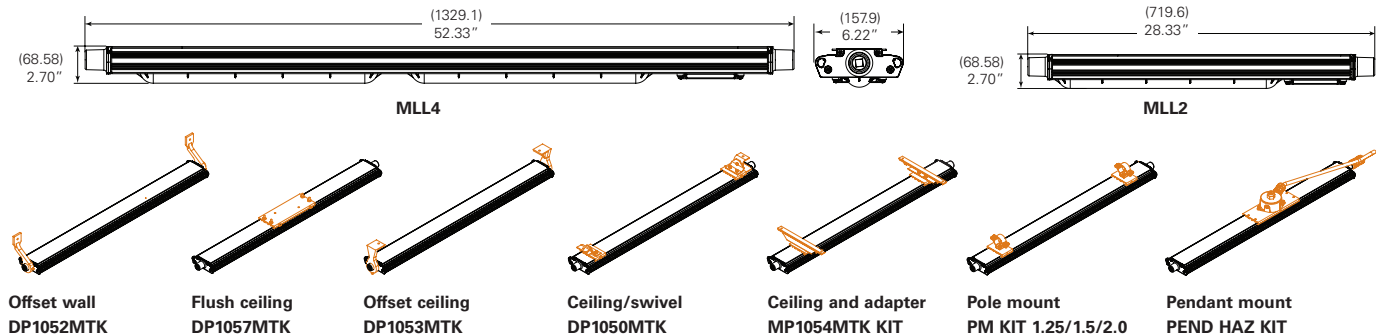

Ⓒ One year warranty. Remote EM kit also available. Available for 4 ft. model only.

Champ MLL LED Luminaires

Cl. I, Div. 2, Groups A, B, C, D
Cl. I, Zone 2
Cl. II, Div. 1, Groups F, G
Cl. III

UL Listed
CSA Certified
Marine & Wet Locations
NEMA 4X; IP66

2L

2L

Mounting options:

Ceiling/swivel mount DP1050MTK

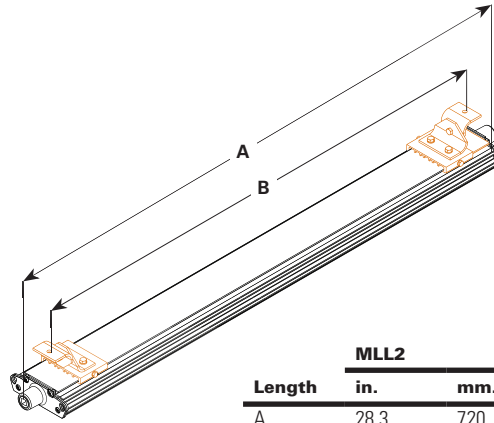
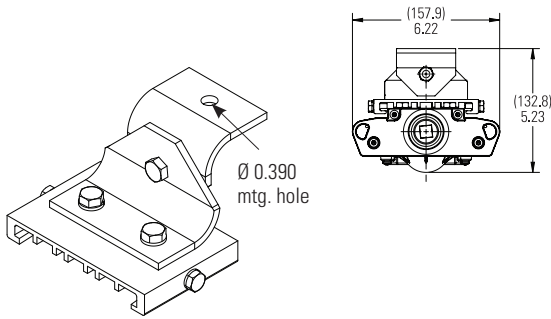

Length	MLL2		MLL4	
	in.	mm.	in.	mm.
A	28.3	720	52.3	1329
B	9-27	222-681	9-51	222-1289

Pole mount PM KIT 1.25/1.5/2.0

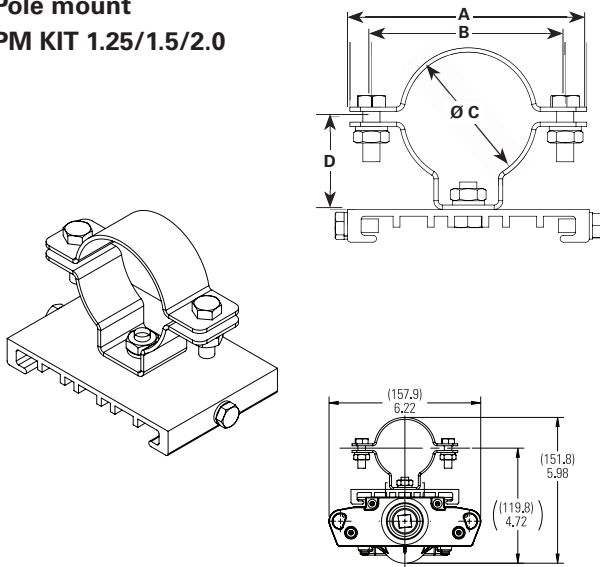

Configuration	ALL MEASUREMENTS IN INCHES			
	A	B	C	D
PM KIT 1.25	4.331	3.543	1.680	1.693
PM KIT 1.5	3.740	2.953	2.000	1.535
PM KIT 2.0	3.386	2.598	2.360	1.378

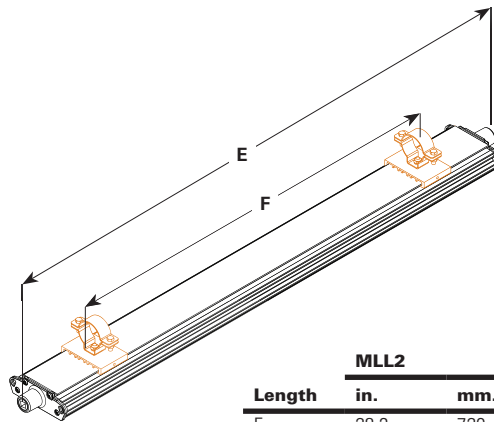

Length	MLL2		MLL4	
	in.	mm.	in.	mm.
E	28.3	720	52.3	1329
F	12-21	305-533	24-45	610-1143

MagnaPro mount MP1054MTK KIT

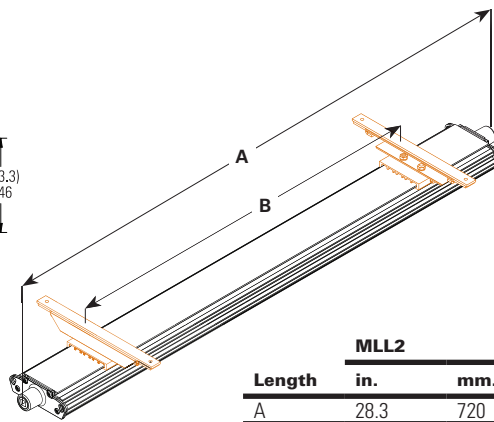
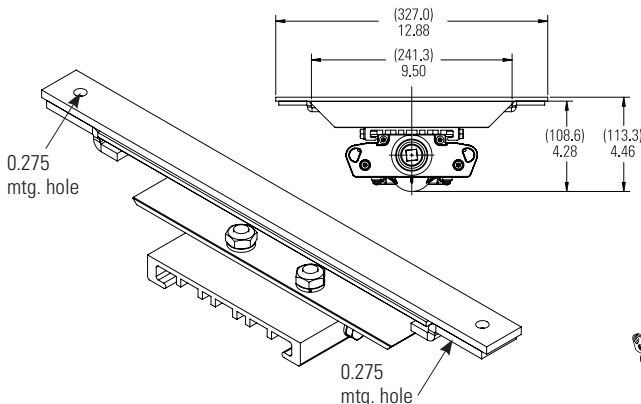

Length	MLL2		MLL4	
	in.	mm.	in.	mm.
A	28.3	720	52.3	1329
B	12-22	305-559	24-46	610-1168

Champ MLL LED luminaires

Cl. I, Div. 2, Groups A, B, C, D
Cl. I, Zone 2
Cl. II, Div. 1, Groups F, G
Cl. III

UL Listed
CSA Certified
Marine & Wet Locations
NEMA 4X; IP66

2L

2L

Mounting options (continued):

Offset wall DP1052MTK

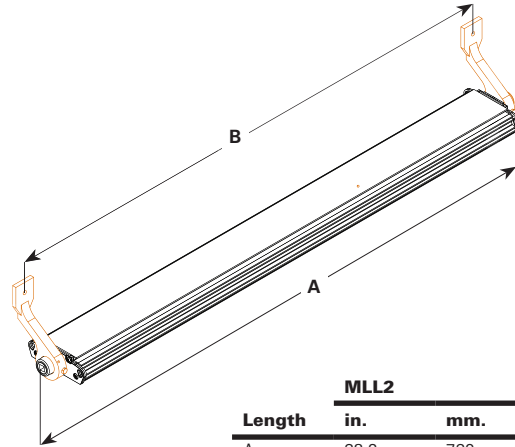
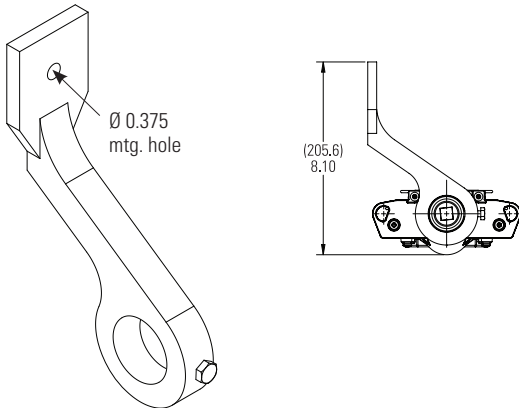

Length	MLL2		MLL4	
	in.	mm.	in.	mm.
A	28.3	720	52.3	1329
B	26.3	669	50.3	1278

Offset ceiling/wall mount DP1053MTK

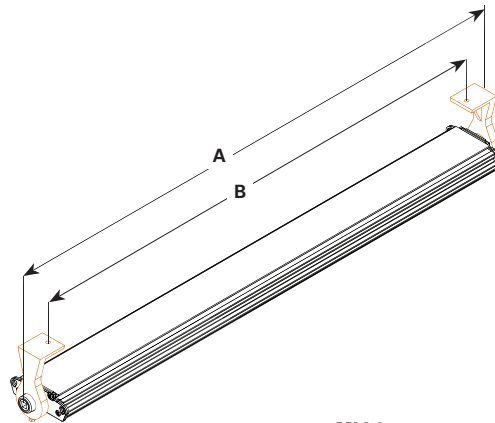
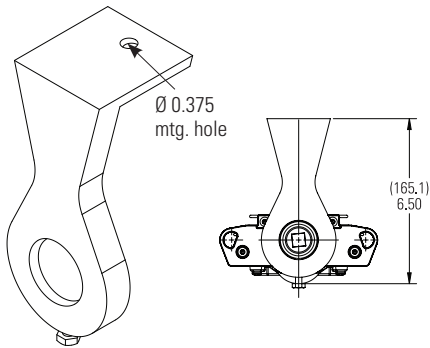

Length	MLL2		MLL4	
	in.	mm.	in.	mm.
A	28.3	720	52.3	1329
B	26.3	584	47.0	1194

Flush ceiling DP1057MTK

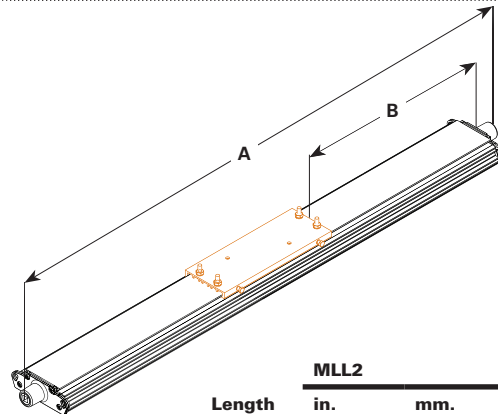
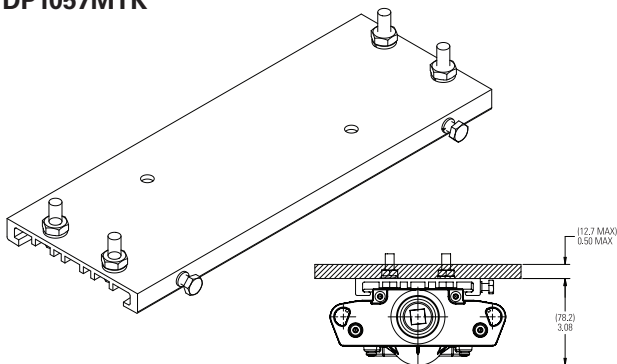

Length	MLL2		MLL4	
	in.	mm.	in.	mm.
A	28.3	720.0	52.3	1329.0
B	6.2	157.5	18.2	462.0

Champ MLL LED Luminaires

Cl. I, Div. 2, Groups A, B, C, D
Cl. I, Zone 2
Cl. II, Div. 1, Groups F, G
Cl. III

UL Listed
CSA Certified
Marine & Wet Locations
NEMA 4X; IP66

2L

2L Mounting options (continued):

Pendant mount – Class I, Division 2 only
PEND HAZ KIT

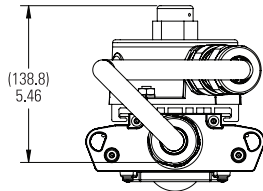
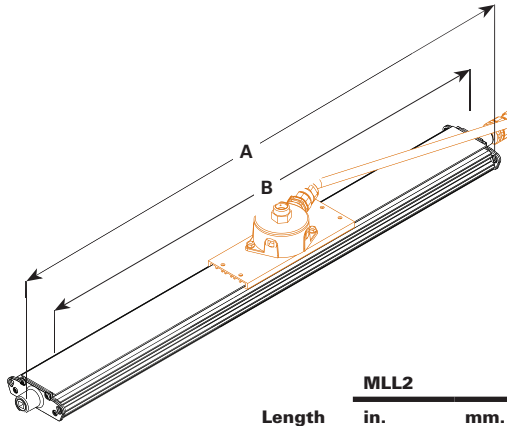
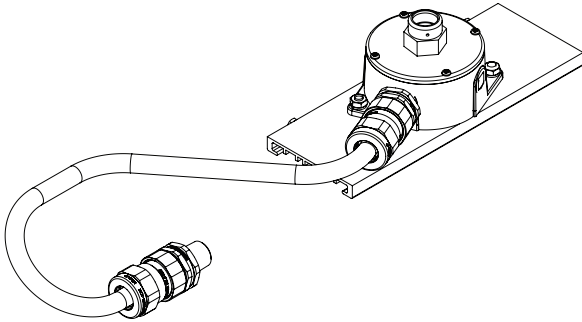

Length	MLL2		MLL4	
	in.	mm.	in.	mm.
A	31.7	805	55.8	1418
B	28.3	720	52.3	1329
C	4.2	108	16.0	406
D	12.2	310	24.0	610
E	34.9	886	58.9	1495

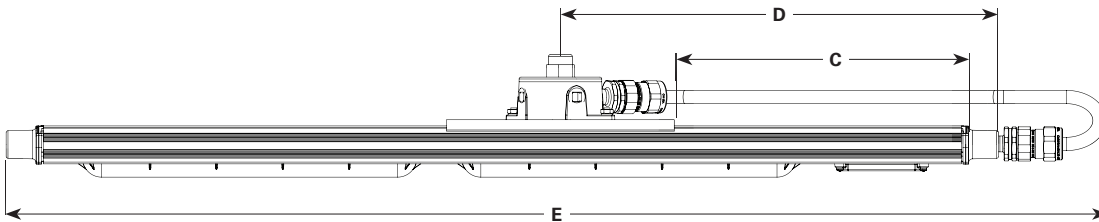

Champ MLL LED luminaires

Integral battery back-up

Cl. I, Div. 2, Groups A, B, C, D
Cl. II, Div. 2, Groups F, G

UL Listed
CSA Certified
Wet Locations
Type 4X; IP66

2L

Champ MLL linear LED luminaires are available with an integral battery back-up module. Virtually the same size as the standard 4 foot model and 90 minutes of emergency lighting to keep your facility and personnel safe.

Model	EM output	Normal output
MLL4/UNV1 EM1	1,400 lumens (100-277V)	6,720 lumens (100-277V)

Applications:

- Egress and emergency lighting for areas requiring uninterrupted lighting during power failure
- Hazardous rated indoor and outdoor emergency lighting in manufacturing plants, heavy industrial, chemical and petrochemical facilities, platforms, loading docks and parking areas

Features:

- Operating ambient: 0°C to +40°C
- 90-minute run time in emergency mode
- 6,720 lumen output for normal operation; 1,400 lumen output in emergency mode
- 50,000 hours rated life at 40°C
- IP66 rated enclosure
- LED indicator to check battery operation
- Nickel cadmium battery
- 1 year warranty

Certifications and compliances:

NEC/CEC:

- Class I, Division 2, Groups A, B, C, D
- Class II, Division 2, Groups F, G
- Wet locations, Type 4X, IP66

UL standards:

- UL844 – Hazardous (Classified)
- UL1598 – Luminaires
- UL1598A – Marine
- UL924 – Emergency Lighting

CSA standard:

- CSA C22.2 Nos. 250, 137, 141

Dimensions:

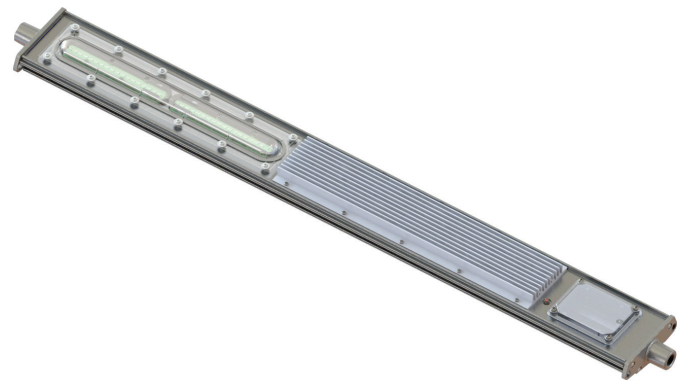
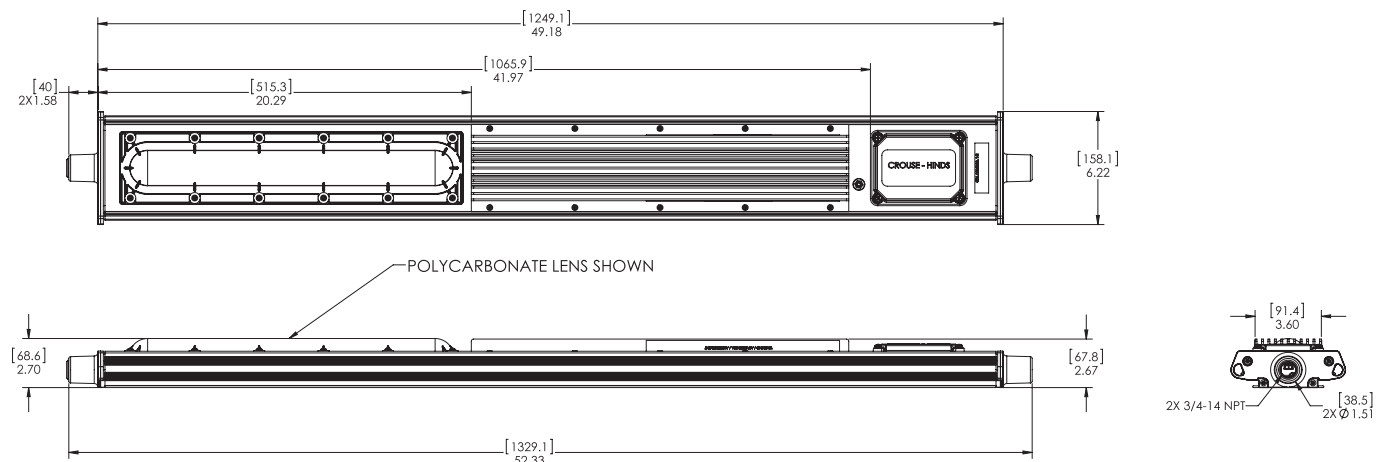

Electrical ratings:

	EM output	Normal output
Voltage	120	277
Amperage at 120 VAC	0.480	0.212
Wattage at 120 VAC	57.8	57.7
Lumen output	1,400	6,720
Frequency	50/60 Hz	50/60 Hz
Power factor at 100 VAC	0.997	0.980
THD	6.58	11.70

Temperature performance data:

Ambient temp. °C	Min. temp. supply wire °C	Simultaneous rating		
		Class I, Div. 2	Class II, Div. 1	Class I, Div. 2; Class II, Div. 1
40	60	T5	T6	T5

Photometrics:

- Complete photometrics can be found at www.crouse-hinds.com/photometrics